



INDEXED _____
FOLLOW UP _____
PROOFED _____
SCANNED _____

PREPARED BY AND RETURN TO: JEFFREY M. KRUEGER P.L.S., KUEHL AND PAYER LTD., 423 WEST MAIN ST., SAC CITY, IA 50583 PH. (712)662-7859

UNITED STATES PUBLIC LAND SURVEY CORNER CERTIFICATE OF

LAND SURVEY MONUMENTS SITUATED IN SECTION 32, TOWNSHIP 85 NORTH,
RANGE 41 WEST, OF THE 5TH PRINCIPAL MERIDIAN, CRAWFORD COUNTY, IOWA.

PREVIOUSLY RECORDED IN BOOK _____ PAGE _____

MONUMENT DESCRIPTION AND REMARKS:

1.) W 1/4 CORNER 32-85-41: FOUND 5/8" REBAR 6" DEEP

PLAN - VIEW

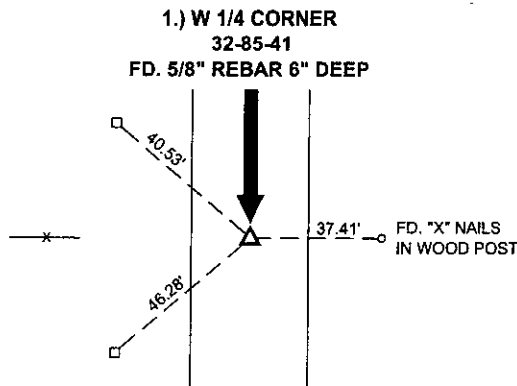
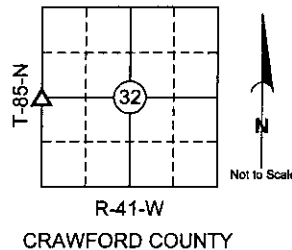

□ = 5/8" REBAR WITH ALUM. CAP
STAMPED "SECTION CORNER
REF. PT."



I hereby certify that this land surveying document was prepared and the related survey work was performed by me or under my direct personal supervision and that I am a duly licensed Land Surveyor under the laws of the State of Iowa.

Jeffrey M. Krueger 2-17-2006
Jeffrey M. Krueger Date:
License Number 16749
My license renewal date is December 31, 2006
Pages covered by this seal 1

List Corners to be Indexed

Corners	Section	Township	Range
1) W 1/4	32	85	41